

Valtek VL-C Spring Cylinder Linear Actuators

GENERAL INFORMATION

The following instructions are designed to assist in installing, troubleshooting and servicing Valtek VL-C spring cylinder linear actuators sizes 100, 150 and 200. Separate installation, operation and maintenance instructions cover 25 and 50 sizes as well as additional features (such as handwheels, limit stops, fail-safe systems or limit switches). Product users and maintenance personnel should thoroughly review this bulletin prior to installing, operating or disassembling the actuator.

This publication does not contain information on Flowserve positioners. Refer to the appropriate installation operation and maintenance instructions for installing, maintaining, troubleshooting, calibrating and operating Flowserve positioners.

To avoid possible injury to personnel or damage to valve parts, WARNING and CAUTION notes must be strictly followed. Modifying this product, substituting non-factory or inferior parts or using maintenance procedures other than outlined could drastically affect performance, void product warranties and be hazardous to personnel and equipment.

WARNING: Standard industry safety practices must be followed when working on this or any process control product. Specifically, personal protection and lifting devices must be used as warranted.

Unpacking

While unpacking the actuator, check packing list against materials received. Lists describing the actuator and accessories are included in each shipping container.

1. Position the lifting straps and hoist to avoid damage to the tubing and mounted accessories when lifting the actuator from the shipping container.

WARNING: When lifting an actuator with lifting straps through the yoke legs, be aware the center of gravity may be above the lifting point. Therefore, support must be given to prevent the actuator from rotating or causing serious injury to personnel or damage to nearby equipment.

2. Contact your shipper immediately in the event of shipping damage.
3. Contact your Flowserve representative with any problems.

Installation

Prior to installation, make sure adequate overhead clearance for the actuator is provided to allow for proper removal from the valve body and for proper maintenance. Refer to Table I.

**Table I:
Overhead Clearance for Maintenance**

Actuator Size	Minimum Clearance
100, 150, 200	9 inches

NOTE: If an actuator is attached to a valve body assembly, see the appropriate installation, operation, maintenance instructions.

1. Connect the air supply and instrument signal air lines to the two marked connections on the positioner. Since both the cylinder and positioner are suitable for 150 psi (10.3 bar) air supply, an air regulator should not be used unless the supply exceeds 150 psi (10.3 bar).

NOTE: In some cases, air supply must be limited to 100 psi (6.9 bar) rather than 150 psi (10.3 bar); this will be indicated by a sticker found near the upper air port on the cylinder.

WARNING: To avoid personal injury or equipment damage, do not exceed recommended supply pressure.

2. Installation of an air filter on the supply line is recommended.
3. Use a soap solution to make sure all air connections are leak-free.

MAINTENANCE

At least once every six months, check for proper operation by following the preventative maintenance steps outlined below. *These steps should not be performed while the actuator is in service.* If an internal problem is suspected with the actuator, refer to the *Disassembly and Reassembly* section.

WARNING: To avoid serious injury, the following steps should only be performed with the air supply or positioner input disconnected.

1. When disconnecting air supply, observe actuator for correct fail-safe action.
2. Examine the actuator for damage caused by corrosive fumes and process drippings.
3. Clean the actuator and repaint any areas of severe oxidation.
4. If possible, stroke the actuator and check for smooth, full-stroke operation.

WARNING: To avoid serious injury, keep hands, hair and clothing away from all moving parts while operating the actuator.

5. Make sure positioner mounting bolts, linkage and stem clamp are fastened securely.
6. Ensure all accessories, brackets and associated bolting are fastened securely.
7. Check rubber bellows for wear.
8. Spray soap solution around the base and top of the cylinder, the adjusting screw and the lower actuator stem bushing to check for air leaks through the O-rings and gasket.
9. Clean any dirt or foreign material from the actuator stem.
10. If an air filter is supplied, isolate the air filter, then check and replace cartridge as necessary.

DISASSEMBLY AND REASSEMBLY

Disassembling the Actuator

Refer to Figures 1 through 4 to disassemble the cylinder actuator.

1. Shut off air supply. If actuator is installed on a Flowserve valve, remove the valve per the appropriate installation operation, maintenance instructions.

WARNING: To avoid serious injury, depressurize the line to atmospheric pressure and drain all fluids before working on the actuator.

2. Disconnect all tubing. Remove stem clamp and stem bellows from the actuator stem.
3. Relieve spring compression by completely removing the adjusting screw. Remove adjusting screw gasket from adjusting screw.

WARNING: To avoid serious personal injury, relieve the spring compression before further disassembly. The cylinder end cap may fly off the yoke when removing the cylinder tie-rod nuts.

4. Remove the four self-locking tie rod nuts by unscrewing in an alternating pattern. Remove the cylinder end cap.
5. Lift the cylinder off the yoke and piston. If excessive O-ring resistance is felt, use a rubber mallet to gently tap around the cylinder perimeter.

WARNING: To avoid serious personal injury, do not use air pressure to remove the cylinder. The cylinder may fly off the yoke.

CAUTION: When removing the actuator stem lock nut, do not hold the actuator stem with a pipe wrench as the sealing surface may be damaged; instead, use a wrench on the flats of the actuator stem.

6. For air-to-retract configurations, remove the spring(s) and spring button for cleaning and inspection (see Figures 1, 3 and 4). Remove the actuator

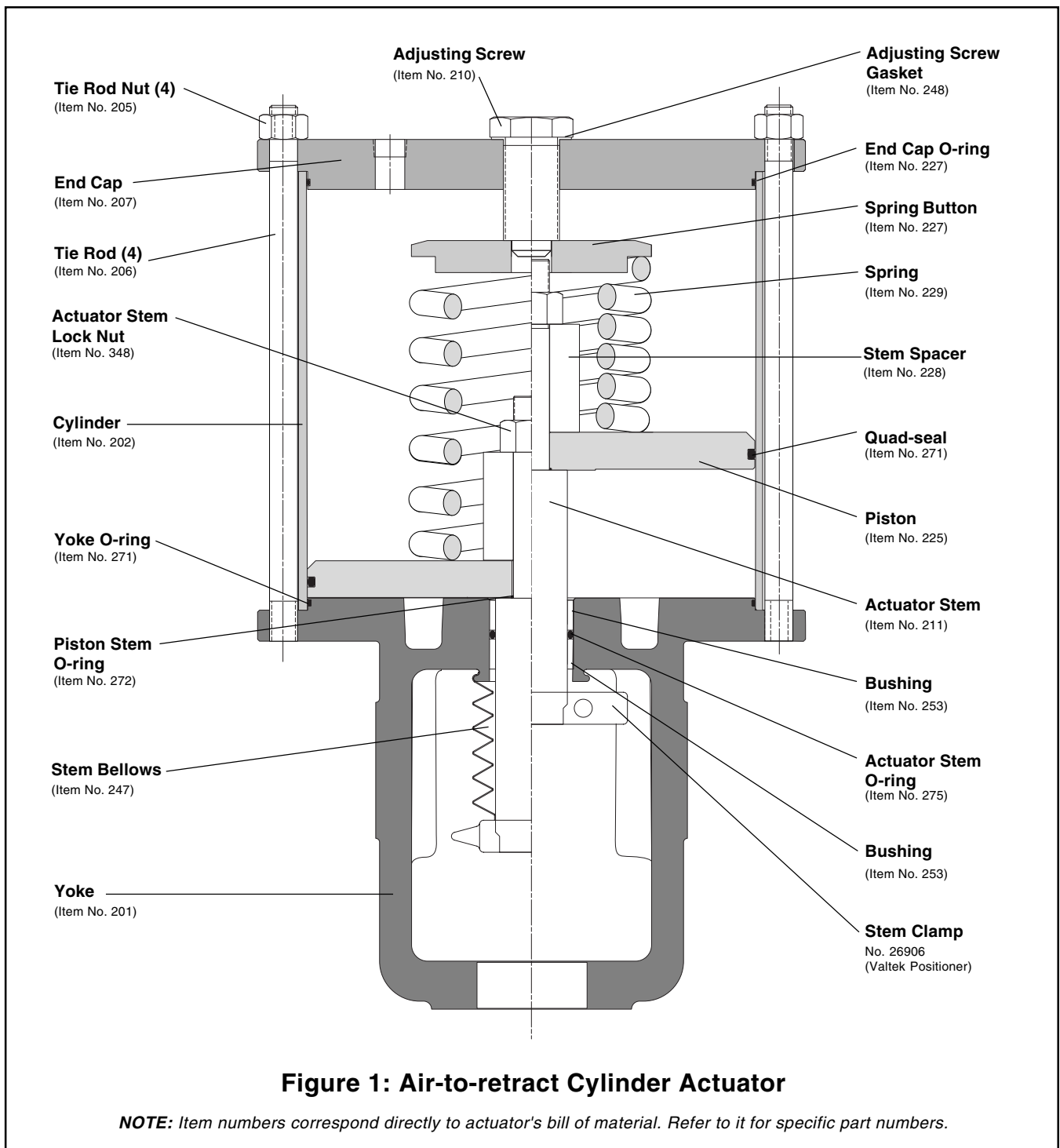

stem locknut by holding the flats on the actuator stem and slide the piston and stem spacer off the actuator stem. The spring guide should be removed when using dual or heavy-duty spring designs.

NOTE: The dual spring configuration (Figure 3) has two springs, one inside the other. Remove both springs during this step.

7. For air-to-extend configurations, slowly loosen and remove the actuator stem locknut and piston.

(Remove the piston and stem locknut together, making sure the piston does not bind on the actuator stem.) Next, remove the spring button, spring and stem spacer.

WARNING: To avoid personal injury, be certain the spring force is completely relieved before removing actuator stem locknut.

8. Remove the piston quad-seal, piston stem O-ring and yoke O-ring.

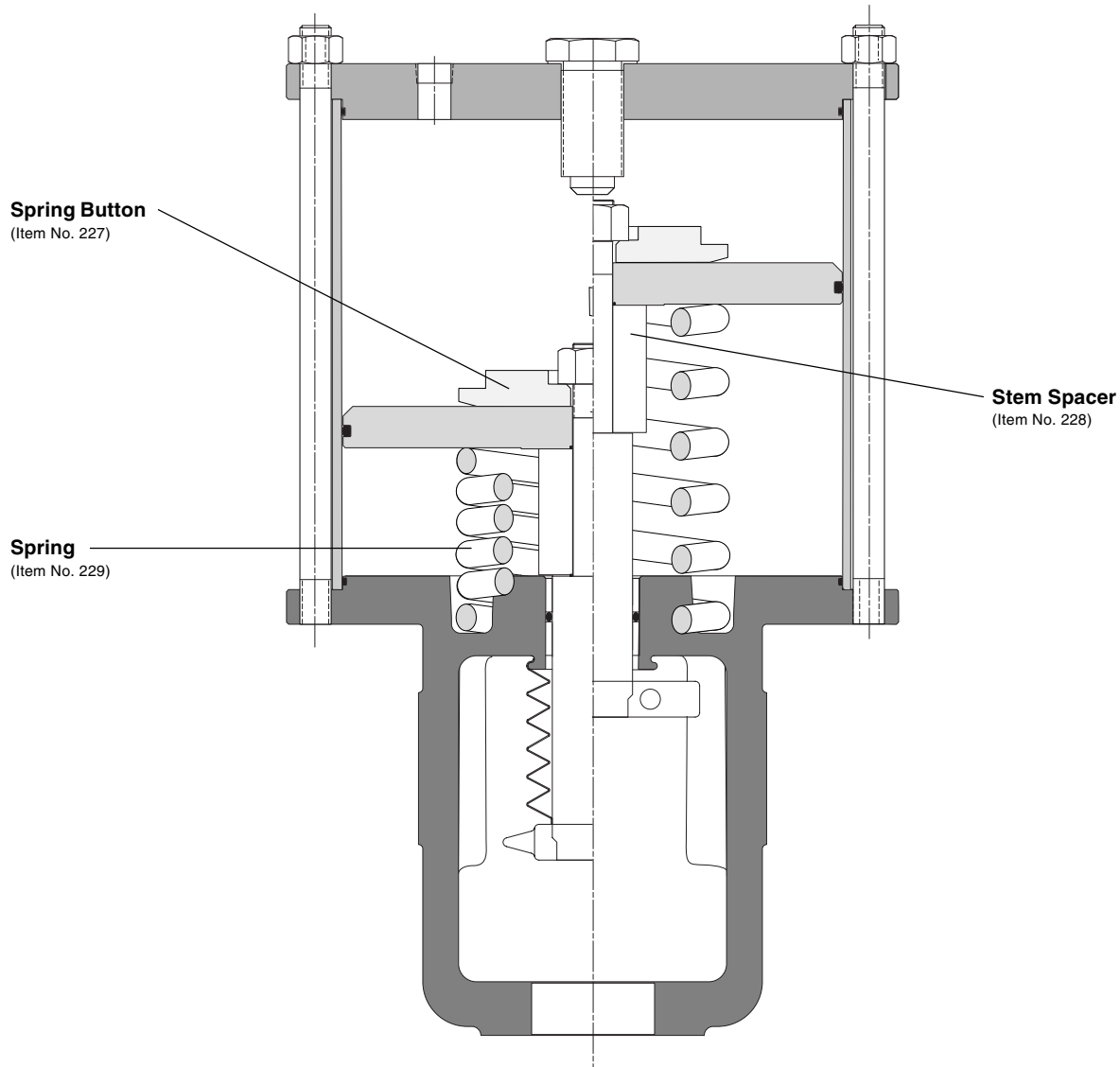

Figure 2: Air-to-extend Cylinder Actuator

NOTE: Item numbers correspond directly to actuator's bill of material. Refer to it for specific part numbers. Parts listed change location upon reversing air action. No new parts are required.

9. Remove the actuator stem O-ring.

NOTE: The stem bushing is pressed into the yoke. The actuator stem O-ring can be replaced without removing the bushing.

10. Use an appropriately sized press to push a worn or damaged bushing out of the yoke.

Reassembling the Actuator

To reassemble the cylinder actuator, refer to Figures 1 through 4:

1. All O-rings and the quad-seal should be replaced and lubricated with a calcium complex grease (DuBois MPG-2 or equivalent). Silicone O-rings must be lubricated with Magnalube-G lubricant or equivalent.
2. Thoroughly clean all internal parts before beginning assembly. Check the cylinder bore for scratches, pitting or worn areas. Lubricate cylinder wall and all internal surfaces with the appropriate lubricant.

NOTE: Applying a light coating of lubricant to the

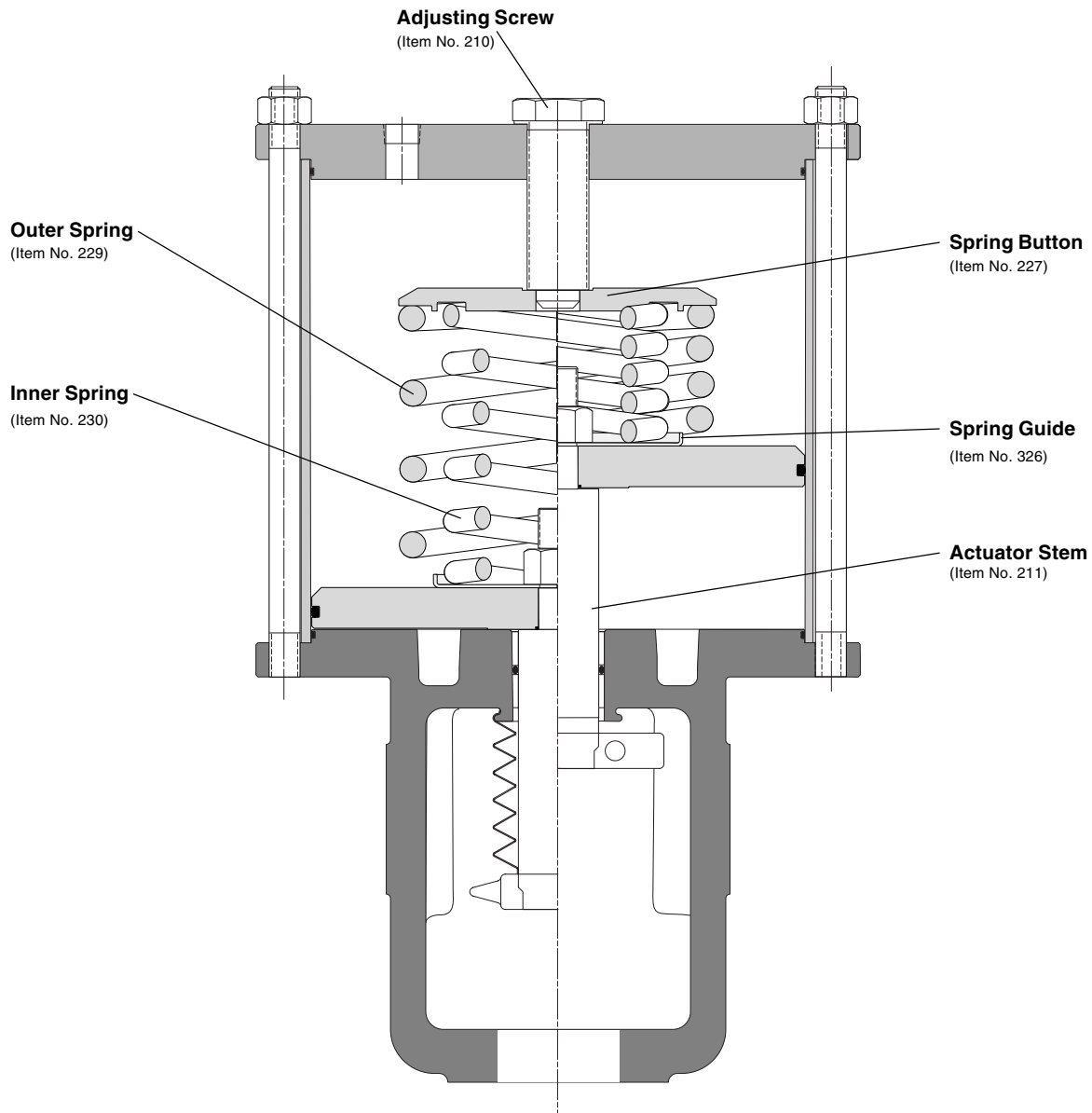

Figure 3: Dual-spring Cylinder Actuator

NOTE: Item numbers correspond directly to actuator's bill of material. Refer to it for specific part numbers. Parts listed indicate differences from the single-spring model.

entire cylinder bore, end cap and both sides of the piston enables smooth operation and can help reduce corrosion.

3. Lubricate the outside of the replacement bushing if the stem bushing has been removed. Press a new lower stem bushing into the actuator stem bore in the yoke until it bottoms out. Press the upper stem bushing into the bore until it is flush with the top of the yoke (refer to Figures 1 or 2).
4. Replace the actuator stem O-ring and yoke O-ring.

NOTE: When installing the actuator stem, align the actuator stem flats with the yoke legs. This allows the stem clamp to work properly and helps prevent plug assembly rotation.

CAUTION: When installing the actuator stem lock nut, do not hold the actuator stem with a pipe wrench as the sealing surface may be damaged; instead, use a wrench on the flats of the actuator stem.

5. Reassemble the piston, piston stem O-ring and

stem spacer on the actuator stem according to the proper air-action (see either Figure 1 or 2). Replace the piston quad-seal. Air-to-extend configurations require the spring button to be stored under actuator stem locknut. Tighten the locknut firmly by holding the flats on the actuator stem.

NOTE: *When reassembling dual or heavy-duty spring actuators, the spring guide must be first inserted under the actuator stem locknut (see Figures 3 and 4).*

6. For air-to-extend configurations, place the spring under the piston and insert the actuator stem through the yoke, being careful not to pinch the actuator stem O-ring or gall the stem and stem bushing. For air-to-retract configurations, insert the actuator stem through the yoke and place the spring(s) and spring button above the piston.
7. Install the tie rods into the yoke using Loctite No. 242 NSF61 or equivalent.
8. Install the cylinder, making sure the cylinder is completely seated on the yoke. Care should be taken not to scar or cut the piston and yoke O-rings.
9. Replace the cylinder end cap and secure to the tie rods using new self-locking nuts. Refer to Table II for the appropriate torque values.

WARNING: To avoid personal injury, the cylinder end cap must be solidly in place. The cylinder end cap may fly off when pressurized.

10. Reinstall the adjusting screw fitted with a new adjusting screw gasket.

NOTE: *Be certain the hole in the spring button is directly centered under the adjusting screw hole in the cylinder on air-to-retract configurations.*

11. Tighten the adjusting screw enough to provide an air seal with the gasket. Do not overtighten.

Table II: Tie Rod Nut Torque Values

Actuator Size	Torque Value (ft.-lbs.)
100	207 – 229
150, 200	336 – 371

12. Reinstall the stem bellows and stem clamp.

NOTE: *To ensure maximum clamping strength when installing the stem clamp, make sure the stem clamp bolting is perpendicular to one of the slots machined into the actuator stem.*

13. Apply air over the piston. Tighten the stem clamp bolting with the stem clamp adjusted to point at the closed position of the stroke indicator plate.

NOTE: *If the actuator is installed on a Flowserve valve, refer to the appropriate installation, operation, maintenance instructions for correct plug stem thread engagement.*

14. Reconnect tubing, supply and signal lines.

Reversing the Air-action

To change the air action from air-to-retract to air-to-extend, or vice versa, refer to Figures 1, 2 or 4:

NOTE: *Dual spring actuators are not reversible.*

1. Disassemble the actuator according to the *Disassembling the Actuator* section.
2. For air-to-retract action, reassemble the actuator with stem spacer and spring button over the piston.
3. For air-to-extend action, reassemble with spring and stem spacer below the piston and with the spring button stored above the piston.
4. Reassemble the actuator according to the *Reassembling the Actuator* section.
5. The positioner must also be reversed. See the appropriate positioner maintenance instructions.

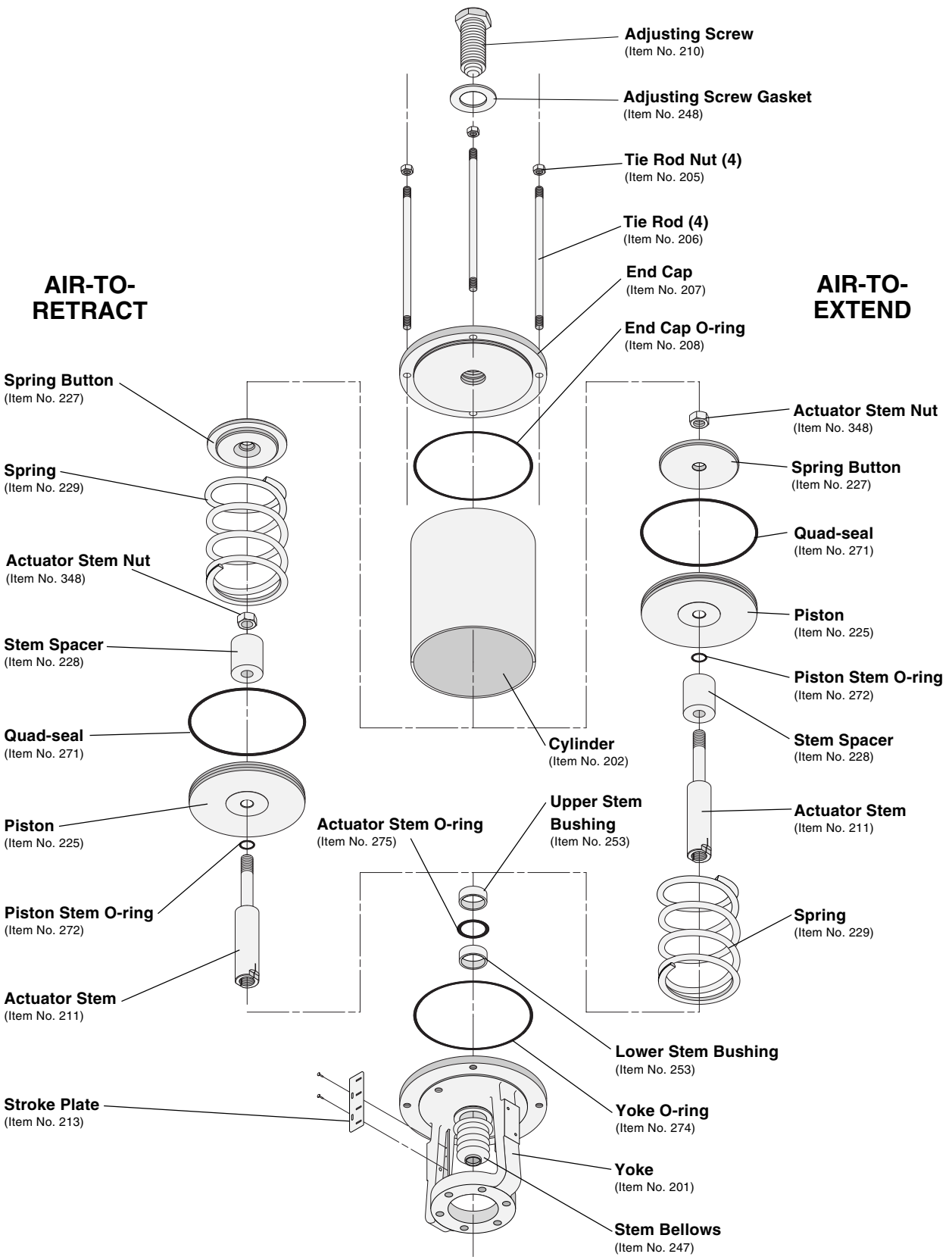

Figure 4: Exploded View, Spring Cylinder Actuator

NOTE: Item numbers correspond directly to actuator's bill of material. Refer to it for specific part numbers.

Troubleshooting

Problem	Probable Cause	Corrective Action
High air consumption or leakage	<ol style="list-style-type: none"> 1. Leaks in the air supply or instrument signal system 2. Malfunctioning positioner 3. Leaks through O-rings or adjusting screw gasket 	<ol style="list-style-type: none"> 1. Tighten connections and replace any leaking lines 2. Refer to appropriate positioner maintenance bulletin 3. Replace O-rings or gasket
Actuator does not move to fail position upon loss of air supply pressure	<ol style="list-style-type: none"> 1. Air pressure in cylinder not venting because of faulty positioner 2. Spring failure 3. Internal valve problem 	<ol style="list-style-type: none"> 1. Refer to appropriate positioner maintenance bulletin 2. Replace spring 3. Refer to valve's maintenance bulletin
Jerky or sticking stem travel	<ol style="list-style-type: none"> 1. Insufficient air supply pressure 2. Unlubricated cylinder wall 3. Worn or damaged stem bushings 4. Improperly assembled spring 5. Internal valve problem 	<ol style="list-style-type: none"> 1. Check air supply and any filters or regulators; check for leaking O-rings 2. Lubricate cylinder wall with silicone lubricant 3. Check actuator stem for damage; replace actuator stem, O-ring, and stem bushings, if necessary 4. Disassemble actuator and check cylinder and piston for damage; reassemble actuator correctly 5. Refer to valve's maintenance instructions

Flowserve Corporation has established industry leadership in the design and manufacture of its products. When properly selected, this Flowserve product is designed to perform its intended function safely during its useful life. However, the purchaser or user of Flowserve products should be aware that Flowserve products might be used in numerous applications under a wide variety of industrial service conditions. Although Flowserve can (and often does) provide general guidelines, it cannot provide specific data and warnings for all possible applications. The purchaser/user must therefore assume the ultimate responsibility for the proper sizing and selection, installation, operation and maintenance of Flowserve products. The purchaser/user should read and understand the Installation Operation Maintenance (IOM) instructions included with the product, and train its employees and contractors in the safe use of Flowserve products in connection with the specific application.

While the information and specifications presented in this literature are believed to be accurate, they are supplied for informative purposes only and should not be considered certified or as a guarantee of satisfactory results by reliance thereon. Nothing contained herein is to be construed as a warranty or guarantee, express or implied, regarding any matter with respect to this product. Because Flowserve is continually improving and upgrading its product design, the specifications, dimensions and information contained herein are subject to change without notice. Should any question arise concerning these provisions, the purchaser/user should contact Flowserve Corporation at any of its worldwide operations or offices.

For more information, contact:

For more information about Flowserve and its products, contact www.flowserve.com or call USA 972 443 6500

Regional Headquarters

Quick Response Centers

1350 N. Mt. Springs Prkwy.
Springville, UT 84663
Phone 801 489 8611
Facsimile 801 489 3719

5114 Railroad Street
Deer Park, TX 77536 USA
Phone 281 479 9500
Facsimile 281 479 8511

12 Tuas Avenue 20
Republic of Signapore 638824
Phone (65) 862 3332
Facsimile (65) 862 4940

104 Chelsea Parkway
Boothwyn, PA 19061 USA
Phone 610 497 8600
Facsimile 610 497 6680

12, av. du Québec, B.P. 645
91965, Courtaboeuf Cedex, France
Phone (33 1) 60 92 32 51
Facsimile (33 1) 60 92 32 99

1300 Parkway View Drive
Pittsburgh, PA 15205 USA
Phone 412 787 8803
Facsimile 412 787 1944

Flowserve and Valtek are registered trademarks of Flowserve Corporation.

