

SERIES 830

End-of-Line Combination Conservation Vent & Flame Arrester

- Settings achieved by weight loading
- Sizes 2" (DN 50) through 10" (DN 250)
- Suitable for unconfined, Group D vapor deflagrations
- Reduces costly evaporation losses
- Single body construction with external flame arrester
- Leakage rate of less than 1 SCFH of air at 90% of set point
- Patented, FEP film "Air-Cushioned Seating"
- Low-leak pallet design - certified test reports
- Factory tested / certified for leakage and correct settings
- Available in Aluminum, Ductile Iron and Stainless Steel

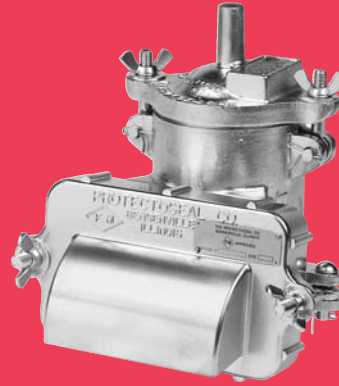

SERIES 830

OBJECTIVE

The Protectoseal Series No. 830 Combination Conservation Vent and Flame Arrester is designed to provide pressure and vacuum relief to maintain tank's vapor space within safe operating parameters. Vent settings minimize loss of product. Under pressure venting conditions, tank vapors are expelled to atmosphere. Also serves as an End-of-Line Flame Arrester to protect tank's vapor space from external sources of ignition.

TECHNIQUE

Pallets in vent housing minimize air and vapor loss as the tank "breathes". They open and close just enough to maintain safe working pressures and avoid damage to the tank. An integral flame arrester protects tank contents against fire and explosion caused by exterior sources of ignition. Rectangular plate-type flame arrester element(s) are mounted external to pallet assemblies for ease of use and are only exposed to vapors when venting.

Peripheral pallet assembly guides and center pallet stem guides insure proper alignment of pallet assembly on the seat and smooth lifting and reseating action.

Optimized Performance Vents™

Protectoseal's "Optimized Performance Vents" incorporate patented features that provide the optimum overall vent performance with regard to sealing, set point, flow and resealing (blow down).

SPECIAL FEATURES

Fast Inspection, Easy Maintenance. "Swing bolt design" permits removal of the vent housing cover and/or weatherhood(s) for easy, convenient handling for inspection and maintenance.

Maintains Accurate Pressure Settings. Set points are accurate to within +/- 3% across the entire range of available settings. Units may be weight loaded for use on installations requiring higher settings.

Air-Cushioned Seating. A flat, smooth diaphragm of FEP film is supported on both sides of an annular channel to form a floating air seal with the seat. An outer support rim assures proper seating.

Automatic Condensate Drainage. Vertically mounted, rectangular plate-type flame arrester is employed for self-drainage of condensate. Grids are mounted externally and are only exposed to vapors when venting.

Low-Leakage. Vent leakage is no more than 1 SCFH at 90% of the set pressure.

Positive Flame Arresting. Correct air spacing between the individual plates is assured through a series of precision embossings on the face of each plate. Each plate is fabricated from heavy gauge metal to resist distortion during cleaning and reassembly.

Sizes Available. 2", 3" and 4" sizes have standard NPT threaded connections. Adapter flanges available in these sizes. 6" (DN 150), 8" (DN 200) and 10" (DN 250) vents mate with standard flanged ANSI connections. Aluminum flanged bodies mate with 125# ANSI flat face flanges and DIN PN 16 flat face flanges. All other material flanged bodies mate with 150# ANSI raised face flanges and DIN PN 16 raised face flanges.

Test Lab Listings. Approved by Factory Mutual Research (FM) in 2", 3" and 4". Listed by Underwriters Laboratories (UL) in 6", 8" and 10".

PRO-FLOW III® Sizing and Selection Software. Use PRO-FLOW III® to select the correct size unit for pressure and vacuum relief calculated in accordance with API 2000, ISO 28300, NFPA 30 and OSHA 1910.106.

Quality Assurance. Each unit is factory tested for leakage and correct settings to meet Protectoseal's high standards prior to shipment.

CONSTRUCTION

A comprehensive range of materials is offered as shown in the chart below. Other materials and features can be furnished upon request.

Available Options.

- Alternate diaphragm materials
- Material certifications for castings
- Lower than standard minimum pressure and /or vacuum setting
- Higher than standard maximum pressure and / or vacuum setting

Series	Housing	Pallet	Pallet Diaphragm	Weight Material
830	Aluminum 356	Aluminum	FEP Film	Steel or Lead
C830	Ductile Iron	316 S.S.	FEP Film	Steel or Lead
E830	Aluminum 356	Aluminum	FEP Film	Steel or lead
F830	S.S. 316	316 S.S.	FEP Film	S.S. or Lead
RE830	Aluminum 356	316 S.S.	FEP Film	Steel or Lead

Note: Aluminum flanged to mate with 125# ANSI and DIN PN 16 flat face flanges. All other materials mate with 150# ANSI and DIN PN 16 raised face flanges.

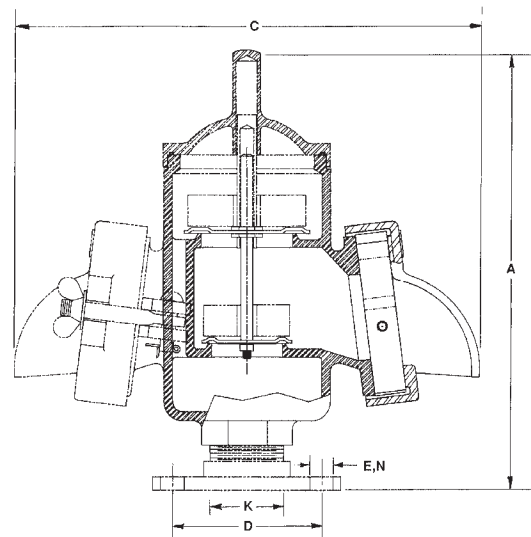
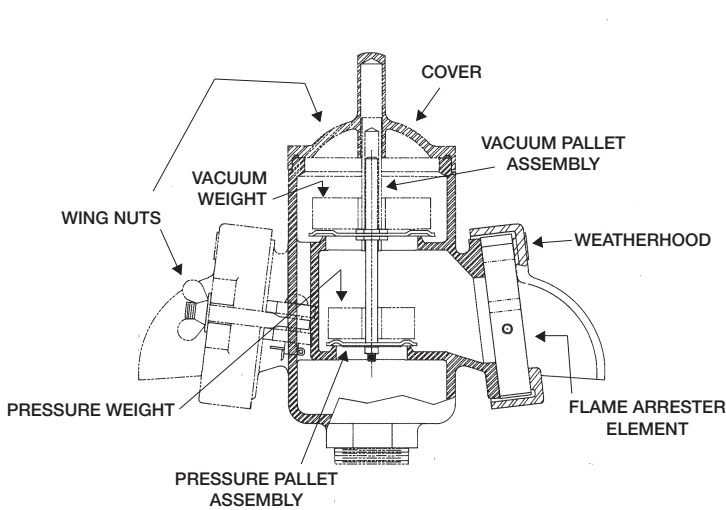

DIMENSIONS & ORDERING INFORMATION (Dimensions shown are for reference only, contact Factory for certified drawings.)

Cat. No.*	Flange K	Connection	Ht. A	Turning Diameter	Length C	B.C. D	Dia. E	Holes N	Test Lab Listing
832H	2"	Threaded	12 $\frac{5}{8}$ "	7 $\frac{3}{4}$ "	10 $\frac{1}{8}$ "	-	-	-	FM
833H	3"	Threaded	14 $\frac{3}{4}$ "	9 $\frac{1}{4}$ "	15 $\frac{5}{8}$ "	-	-	-	FM
834H	4"	Threaded	15 $\frac{3}{4}$ "	11 $\frac{1}{4}$ "	19 $\frac{1}{4}$ "	-	-	-	FM
836C	6"	Flanged	18"	17 $\frac{1}{2}$ "	24 $\frac{3}{4}$ "	9 $\frac{1}{2}$ " -	7 $\frac{7}{8}$ "	8	UL
836DNC	DN150	Flanged	457mm	444mm	629mm	240mm	22mm	8	-
838B	8"	Flanged	22"	19 $\frac{1}{4}$ "	35"	11 $\frac{1}{4}$ "	7 $\frac{7}{8}$ "	8	UL
838DNB	DN200	Flanged	559mm	502mm	889mm	295mm	22mm	12	-
840	10"	Flanged	29"	27"	46"	14 $\frac{1}{4}$ "	1"	12	UL
840DN	DN250	Flanged	737mm	686mm	1168mm	355mm	26mm	12	-

* Cat. No. designates Aluminum Housing & Pallets, please refer to chart on the reverse for other materials of construction.

PRESSURE AND/OR VACUUM SETTINGS (Consult factory for settings outside of STANDARD range.)

Flange Size	STANDARD MINIMUM SETTINGS						STANDARD MAXIMUM SETTINGS*					
	PRESSURE & VACUUM						PRESSURE			VACUUM		
	Aluminum			Other Materials			All Materials			All Materials		
	oz./in. ²	in.W.C.	kPa	oz./in. ²	in.W.C.	kPa	oz./in. ²	in.W.C.	kPa	oz./in. ²	in.W.C.	kPa
2" / DN 50	0.50	0.87	0.22	0.75	1.30	0.32	16.00	27.68	6.89	8.00	13.84	3.45
3" / DN 75	0.50	0.87	0.22	0.75	1.30	0.32	16.00	27.68	6.89	8.00	13.84	3.45
4" / DN 100	0.50	0.87	0.22	0.75	1.30	0.32	16.00	27.68	6.89	8.00	13.84	3.45
6" / DN 150	0.50	0.87	0.22	0.75	1.30	0.32	13.80	23.87	5.95	8.50	14.71	3.66
8" / DN 200	0.50	0.87	0.22	0.75	1.30	0.32	14.90	25.78	6.42	3.60	6.23	1.55
10" / DN 250	0.50	0.87	0.22	0.75	1.30	0.32	29.40	50.86	12.67	9.20	15.92	3.96



225 Foster Ave., Bensenville, IL 60106-1690
 P 630.595.0800 F 630.595.8059
 info@protectoseal.com www.protectoseal.com